

Standard Equipment

- Fully proportional ramp-on controls for boom lift, swing, and drive
- Automatic braking
- 165 degrees hydraulic platform rotation (90 degrees right, 75 degrees left)
- Foam filled tires
- Hydraulically extendable rear axles
- Built-in chassis jack
- 12 volt battery operated emergency power
- Manual bleed down valve
- Driveable at full height
- 5 degrees tilt alarm
- 125 volt GFCI AC outlet at platform
- Aluminum telescoping booms
- Hour meter and ammeter
- Operator horn
- Engine anti-restart control
- Hydraulic oil level and temperature gauges
- High engine temperature and low oil pressure shut-down system
- 60 month warranty

Specifications

Working Height	86' (26.2 m)
Platform:	.
. Height	80' (24.4 m)
. Capacity	500 lbs (227 kg)
. Size	92" x 30" (234 x 76 cm)
. Construction	Steel
Boom Construction:	.
. Base Boom	Steel

. Telescoping Booms	High strength aluminum
Boom Extension	Double acting hydraulic cylinder and dual wire rope cables
Boom Guides	Lubrication free, ultra high molecular weight polyethylene
Pivot Pin Bearings	Lubrication free, composite material
Horizontal Reach	71'1 1/2" (21.7 m)
. Elevation	+70 degrees / -13 1/2 degrees
Hose & Wiring Extension	Telescoping housing attached to sides of booms
Turntable Rotation	360 degrees continuous
Power Source	Gas (LP or Dual Fuel optional) or Diesel Engine
Fuel Capacity	40 US gal (151.4 L)
Hydraulic System Capacity	65 US gal (246 L)
Drive Speeds:	.
. High (booms stowed)	3 mph (4.8 kph)
. Low (booms elevated)	.75 mph (1.2 kph)
Gradeability	25%
Turning Radius:	.
Inside w/axle extended	17'5" (5.3 m)
Height (stowed)	9'7" (2.9 m)
Width (stowed)	8'5 1/2" (2.6 m)
Length (stowed)	38'10" (11.8 m)
Wheelbase	12' (3.7 m)
Tires	15" x 22.5"
. Type	Foam filled, 16 ply rating
Weight (approx.)	30,300 lbs (13,744 kg)

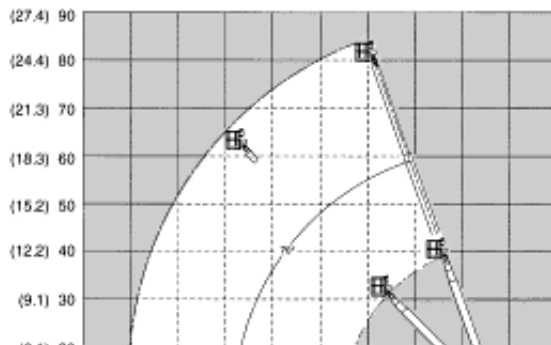

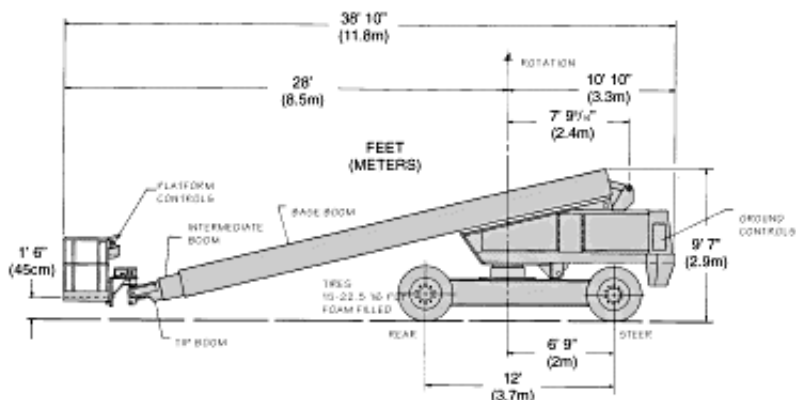
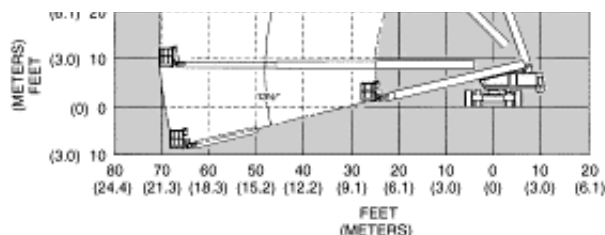

Optional Equipment

- Platform control box cover
- Platform work lights
- Airline to platform
- Flashing light on boom
- Swinging gate
- Sandblast protection kit
- Driving lights
- Dual fuel or LP gas only
- Spark arrestor muffler
- Cold weather start kit
- Hydraulic system cold weather warm-up kit
- AC Generator (Hydraulic powered)
- Drive motion alarm
- Tow kit
- 4-wheel drive (4 x 4) adds mid-range drive speed (1.5 mph, 2.4 kph) 30% gradeability
- Platform option
92"x 30" (234 x 76 cm) Alum. (Capacity 600 lbs., 273 kg)

DANGER: Models described on this page are NON-INSULATED and do not provide electrocution protection from contact with or close proximity to energized conductors which is pointed out on decals and placards attached to the machine.

Only qualified and trained operators are to be authorized to use and operate a work platform.

Aerial work platforms must be elevated only on firm, level surface.

Products in this page comply with applicable ANSI Standards. This page is for illustrative purposes only. Consult Operating/Maintenance and Parts Manuals for proper procedures. Specifications may vary and are subject to change without notice or obligation.

[[TB80](#)]

[[Specifications Sheet](#)]



Copyright (C) 1998 Snorkel, All Rights Reserved.
Web Site Developed by [Digital Lagoon](#).